

### Applications and Key Benefits

- + Front terminal 12V blocs
- + Grid plates with electrolyte in gel guarantee long cycling life  
ideal for:
  - Telecom (BTS) application
  - Applications in areas with unstable power supply
- + Deep discharge proof
- + Front terminal design reduces installation time and facilitates maintenance
- + Fits 23 inch power racks / cabinets (except 12XL205)
- + Allows more compact battery layout
- + Fit for remote venting system
- + Minimal gassing and maintenance free without topping-up
- + Recyclable

### Applicable Standards

- DIN 43539T5 - deep discharge
- IEC 60896 Part 21 - VRLA methods of testing
- IEC 60896 Part 22 - VRLA requirements
- BS 6290 Part 4 - VRLA classification
- Eurobat "Long Life" - 12 years and longer
- UL Recognized

### FIAMM Manufacturing

- ISO 9001 Quality Management System
- ISO 14001 Environmental Management System
- OHSAS 18001 - Workplace Safety & Health

### Technical Features

- Thick pasted plates with high quality lead-tin-calcium alloy for low corrosion and high rate performance
- Electrolyte immobilized in gel structure, filling completely the space between the plates top-to-bottom
- Separators with extremely high porosity and low internal resistance
- ABS IEC 707 FV0 flame retardant plastics
- Container and lid designed for high mechanical strength
- Female M8 terminals guarantee high conductivity, minimum installation time and maximum torque retention
- Flame arrestors expel excess gas and prevent sparks or flames from entering the battery
- Safety valves operate at low internal pressure
- Remote venting system available for applications which require limited gassing to be vented externally



### FIAMM XL range

BATTERY TYPE	NOMINAL VOLTAGE (V)	CAPACITY (AH) Ah at 20°C	SHORT CIRCUIT CURRENT (A)	INTERNAL RESISTANCE (mohm)	DIMENSIONS (mm)			WEIGHT (kg)	TERMINAL TYPE
		10 hrs to 1.80 VPC	IEC 60896-21	IEC 60896-21	Width	Length	Height		
12 XL 105	12	100	2120	5.82	126	558	230	37	Female M8
12 XL 125	12	120	1980	6.24	126	558	270	45	Female M8
12 XL 155	12	150	2080	5.93	126	558	320	54	Female M8
12 XL 205	12	200	2490	4.95	260	500	235	74	Female M8

Note: dimensions may have a natural tolerance of  $\pm 2$ mm

### Discharge AMPERE at 20°C

BATTERY TYPE	NOMINAL CAPACITY 1.80 VPC 10 hours, 20°C	DISCHARGE TIME (hours) end voltage (V)							
		0.5 1.65 VPC	1 1.65 VPC	2 1.70 VPC	3 1.75 VPC	4 1.75 VPC	5 1.80 VPC	8 1.80 VPC	10 1.80 VPC
12 XL 105	100	99	60.2	36.0	24.9	19.8	16.5	11.7	10.0
12 XL 125	120	119	72.2	43.2	29.9	23.7	19.5	14.0	12.0
12 XL 155	150	149	90.3	54.0	37.4	29.7	24.4	17.5	15.0
12 XL 205	200	198	120	72.0	49.8	39.6	32.5	23.4	20.0

### Dimensions

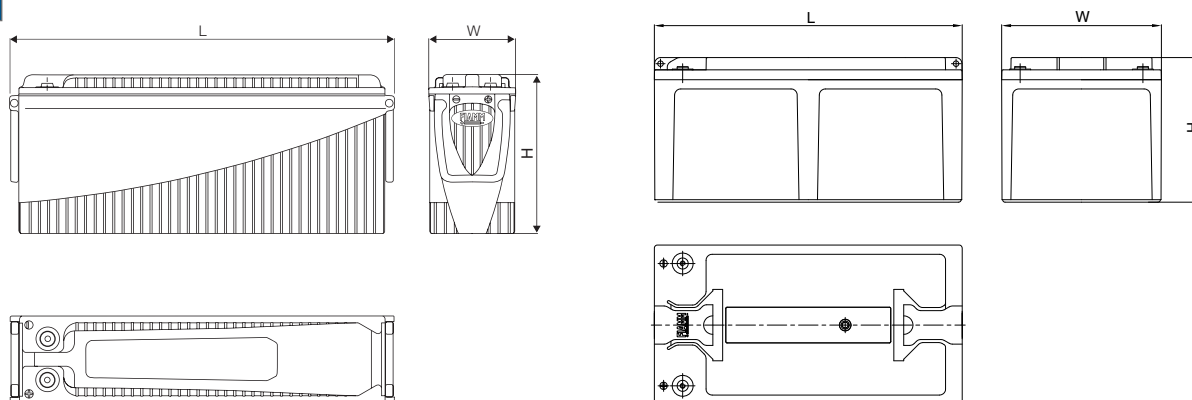

### Electrical Characteristics

- FLOAT VOLTAGE CHARGE AT 20°C: 2.25 V/cell
- BOOST RECHARGE: maximum voltage of 2.35V/cell with the maximum current of  $0.25 \times C_{10}$  (A)
- FLOAT VOLTAGE TEMPERATURE COMPENSATION:  $-2.5 \text{ mV/}^\circ\text{C/cell}$